

# 720.0300.11

Fire Rated Letter Plate Set - FD30/FD60

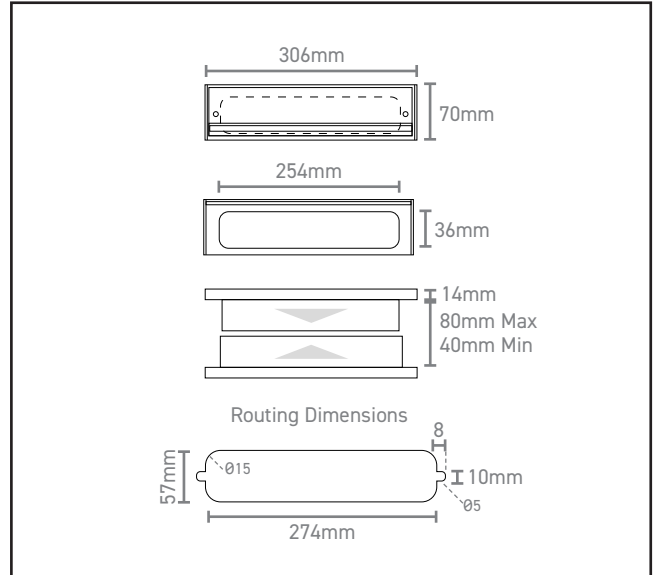

## Product Specification

Letterbox  
Letter Plate Set  
FD30/FD60

Tested to BS 476 part 22: 1987  
Tested to BS 476 Part 31/1: 1983  
PAS 23/24, compliant to BS2911

## Specification

Finish	Satin Anodised Aluminium
Dimensions	306mm (w) x 70mm (h)
Door Thickness	Minimum 40mm - Maximum 80mm
Fire Rated	FD30/60
Smoke Tested	Tested to BS 476 Part 31/1: 1983
Security Tested	Tested to BS 476 Part 31/1: 1983

A robust, commercial, metal framed, telescopic letterbox with metal flaps and fitted with a high performance intumescent liner. In the event of fire the intumescent liner expands rapidly and seals off the letterbox opening, preventing the spread of fire and smoke whilst maintaining the integrity of the fire door assembly.

# 720.0300.03

Fire Rated Letter Plate Set - FD30/FD60

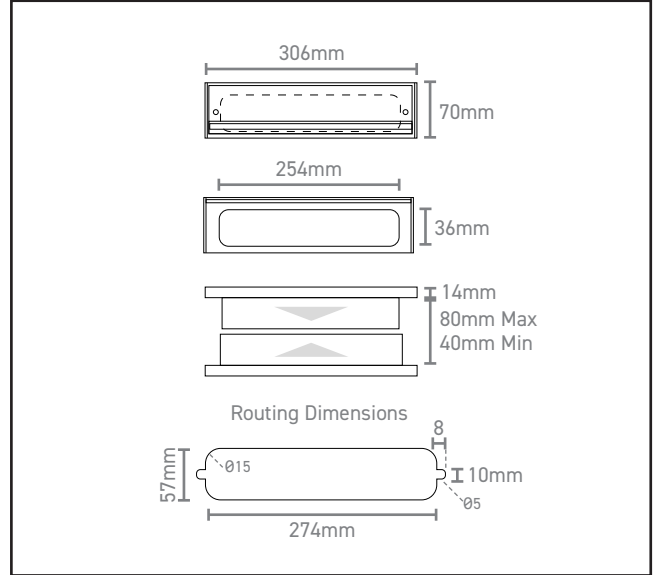

## Product Specification

Letterbox  
Letter Plate Set  
FD30/FD60

Tested to BS 476 part 22: 1987  
Tested to BS 476 Part 31/1: 1983  
PAS 23/24, compliant to BS2911

## Specification

Finish	Gold Finish
Dimensions	306mm (w) x 70mm (h)
Door Thickness	Minimum 40mm - Maximum 80mm
Fire Rated	FD30/60
Smoke Tested	Tested to BS 476 Part 31/1: 1983
Security Tested	Tested to BS 476 Part 31/1: 1983

A robust, commercial, metal framed, telescopic letterbox with metal flaps and fitted with a high performance intumescent liner. In the event of fire the intumescent liner expands rapidly and seals off the letterbox opening, preventing the spread of fire and smoke whilst maintaining the integrity of the fire door assembly.

For more information please contact

01451 824110 | sales@wellinguk.com | www.wellinguk.com

Welling Ironmongery Ltd, Unit R1, Bourton Industrial Park, Bourton on the Water GL54 2HQ