

# 570.6130.39

SG Standard Roller - Anti-Jump - Non-Countersunk

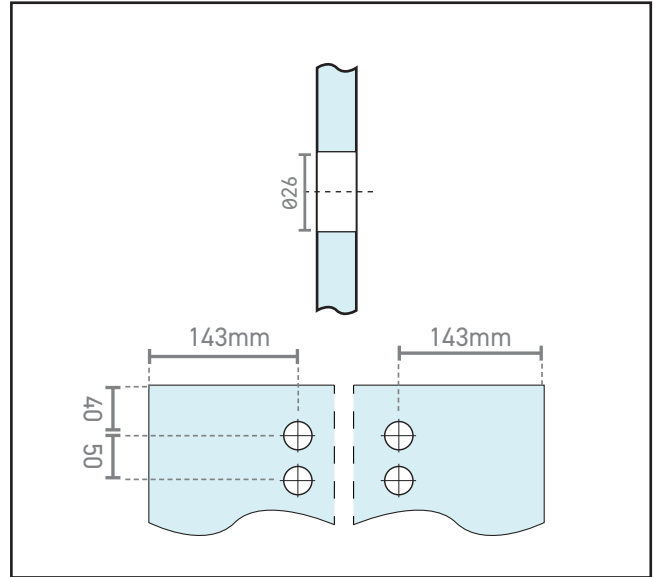
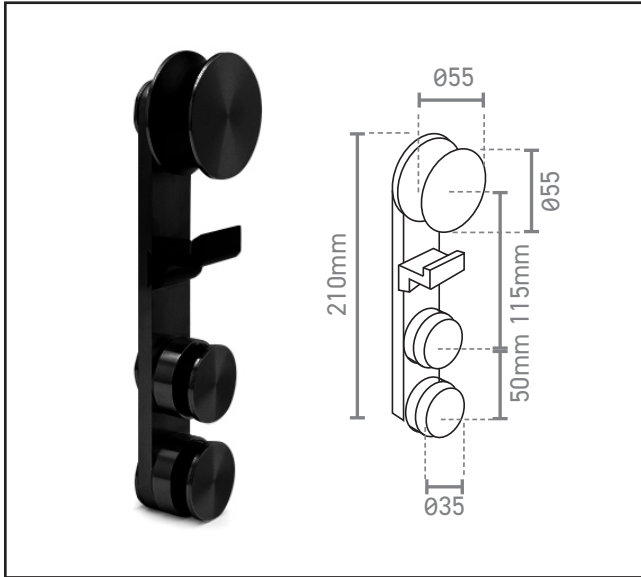

## Product Specification

High quality roller-bearing roller, for our SG glass sliding system  
Anti-Jump version

## Specification

<b>Finish</b>	Matt Black
<b>Glass Thickness</b>	10-12mm
<b>Max Door Width</b>	1200mm (with 2 rollers)
<b>Max Door Weight</b>	100kg (with 2 rollers)
<b>Anti-Jump</b>	Yes

For more information please contact

01451 824110 | sales@wellinguk.com | www.wellinguk.com

Welling Ironmongery Ltd, Unit R1, Bourton Industrial Park, Bourton on the Water GL54 2HQ