

620.3300.01

Securefast Push Button Digital Lock - with Knob - Holdback

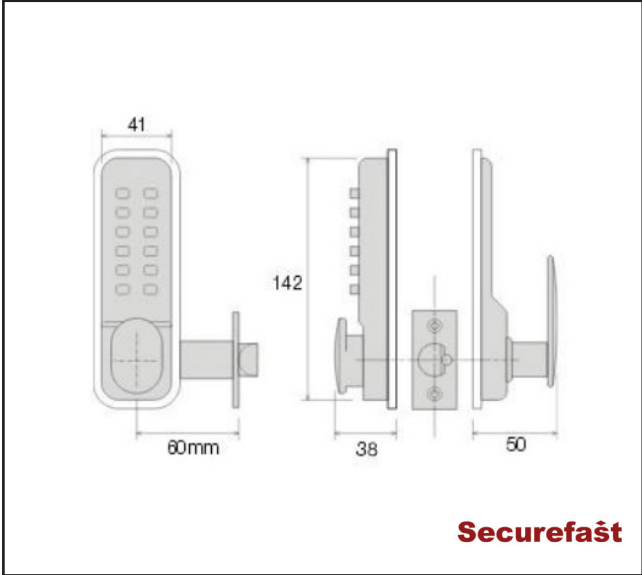

Making Ironmongery Easy



Product Specification

Suitable for light-medium commercial use
EasyCode function allows the lock to have its code changed without having to physically re-arrange the retainers within the mechanism

Hold-back facility allows the latch to be 'held-back' which allows free passage for any length of time - this is then resettable allowing the door to be locked again

Specification

| | |
|-------------------|--------------|
| Finish | Satin Chrome |
| Brand | Securefast |
| Backset | 60mm |
| Holdback Facility | Yes |
| Easy Code Version | Yes |
| | |
| | |
| | |
| | |