

# 530.7004.01

Electromagnetic Dual Function Floorspring Kit - Single Action

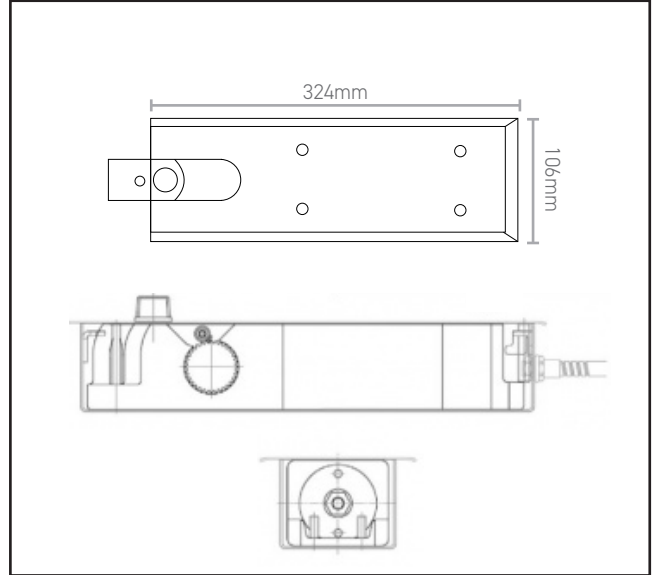

## Product Specification

High quality cam & roller action mechanism  
Operating voltage 24VDC at 125mA =10% -15%.  
Mechanical backcheck at approximately 70°.

Multipoint hold open between approximately 80° and 180° when current is applied.  
Hold Open 80° - 180°

## Specification

Finish	Satin Stainless Steel
Power Size	EN4
Max Door Width	1100mm
Max Door Weight	500kg
Voltage	24v DC
Backcheck	Yes
Hold Open	Yes
Opening Angle	180 degrees
	An electromagnetic Hold open or swing free floorspring. When no current is applied to unit, it will act as a standard hydraulic floor closer. Loss of electrical current due to a signal from a smoke detector or other signalling device will open an electromagnetically controlled valve in the closer and close the door under full hydraulic control. A secondary regulation system protects closer from damage caused by forced closing

For more information please contact

01451 824110 | sales@wellinguk.com | www.wellinguk.com

Welling Ironmongery Ltd, Unit R1, Bourton Industrial Park, Bourton on the Water GL54 2HQ