

Glass door system

Vorbereitung Hydraulischer Eckbeschlag - Türschließer (Set)

Art. Nr.: 29.5049.001.12

Preperation Hydraulic Patch Fitting (Set)

Art. Nr.: 29.5049.002.12

Art. Nr.: 29.5049.003.12

Ausführung:
Options:

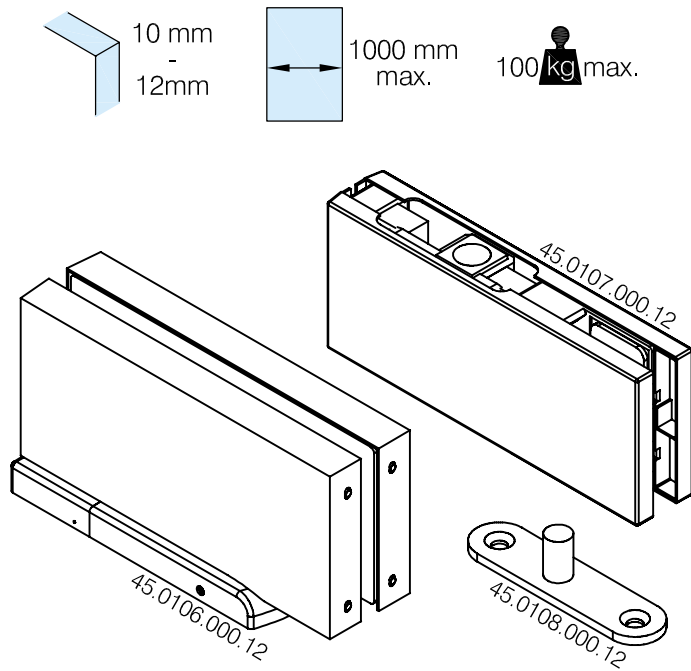

Montagewerkzeug und Material:
Mounting tools and supply:

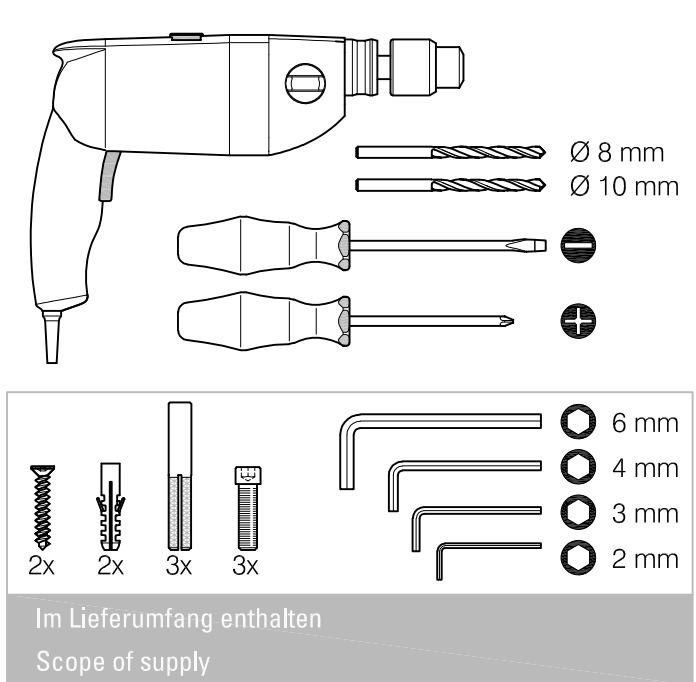

Glasausschnitt für: 45.0106.000.12
Glass cut out for:

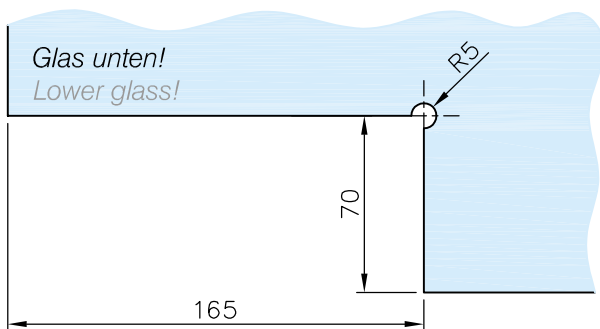

Glasausschnitt für: 45.0107.000.12
Glass cut out for:

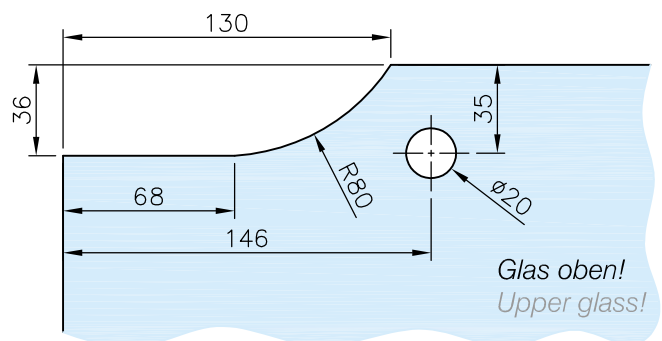

Wichtig: Vor der Montage das Glas im Bereich der Klemmfläche mit handelsüblichem Glasreiniger reinigen.
!!! Keine Verdünnung (Lösemittel) verwenden!

Important: The glass clamping area must be cleaned with a standard glass cleaning fluid before install the lock.
!!! Do not use thinners (solvents)!

Glass door system

Glastür Montage:
Glass door installation:

Stand 09.2020

! Achtung!
Schließen Sie die Tür nicht mit Kraft,
dies kann zur Beschädigungen im
inneren des Beschlags führen.
Note!
Do not close door by force, this can
lead to internal failure of the fitting.

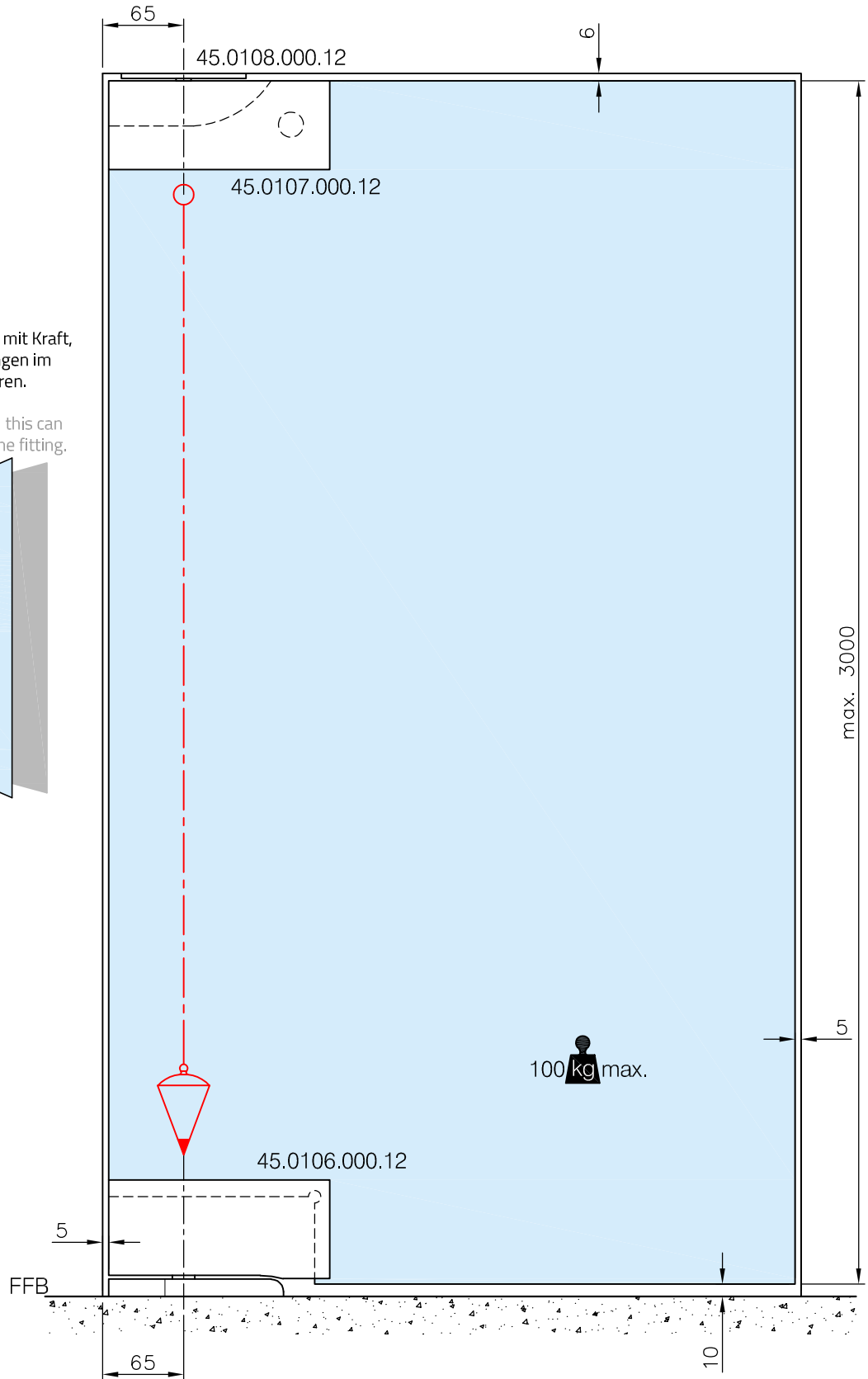

With reservation of printing errors and technical changes. / Druckfehler und technische Änderungen vorbehalten. / Nous ne sommes pas responsable des erreurs d'impression. / Drukfouten en technische veranderingen voorbehouden.

Appearance & Dimension

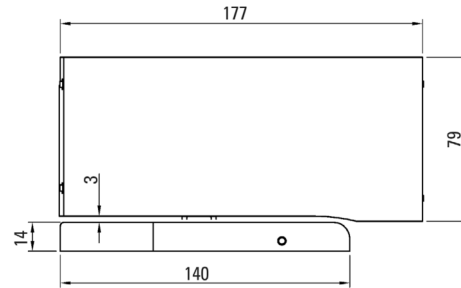
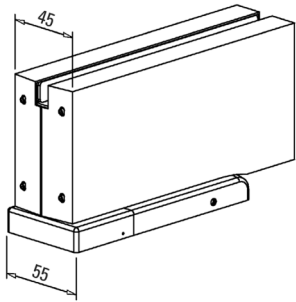

suitable door width ≤ 1000 mm
 max. load capacity 100 kg
 dimension 173 x 52 x 95 mm
 (cover plate not included)

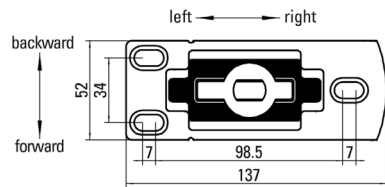

Unique designed base adjustable for:
 ± 5 mm backward and forward
 ± 7 mm left and right
 ± 5° alignment adjustment

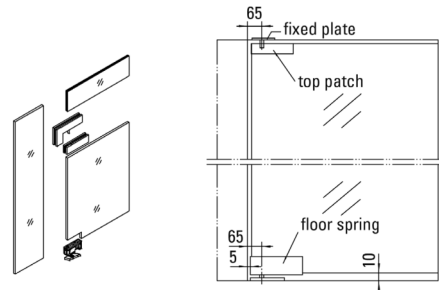
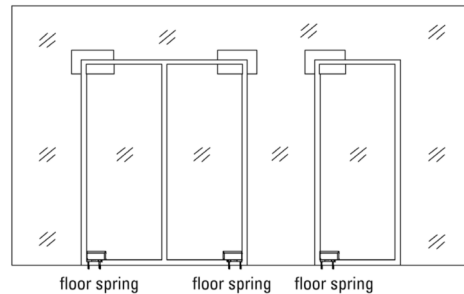

When used with top patch or top pivot, pivot center must be aligned with floor spring pivot center.

Determine the top & bottom shaft center and the installation position for base, keep suitable gap on the side as picture shows.

With reservation of printing errors and technical changes • 18.07.2017

www.g-fittings.com

45.0106.000.12

Oil patch fitting - floor mounted Installation instructions

Base adjustable in all direction

90° hold-open max. opening degree 140°

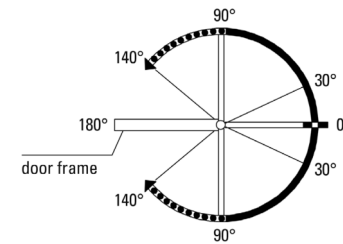

■ Back to close position section
 ●● Hold-open section

Features

1. Close 0°
2. Fast closing 90° - 30° (Section 1)
3. Soft closing 30° - 0° (Section 2)
4. Hold-open 140° - 90°
5. Closing speed adjustable:
 - No.1 valve 90° - 30°
 - No.2 valve 30° - 0°

Component view

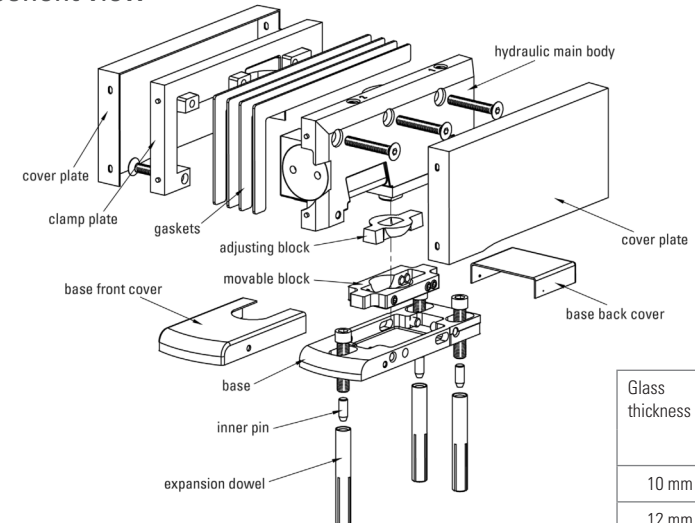

Glass thickness	Gasket quantity and thickness	
	1 mm	2 mm
10 mm	2	2
12 mm	0	2

Installation steps

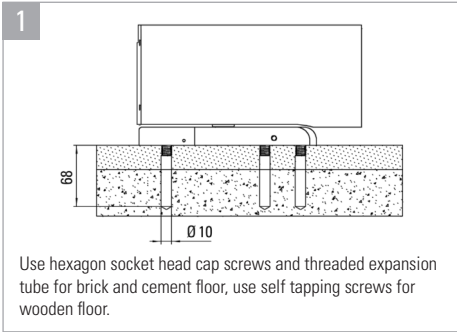

Use hexagon socket head cap screws and threaded expansion tube for brick and cement floor, use self tapping screws for wooden floor.

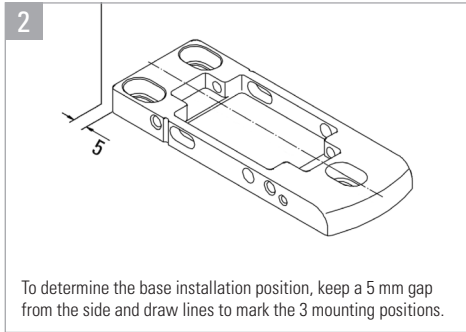

To determine the base installation position, keep a 5 mm gap from the side and draw lines to mark the 3 mounting positions.

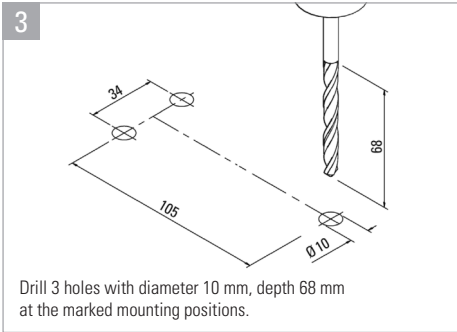

Drill 3 holes with diameter 10 mm, depth 68 mm at the marked mounting positions.

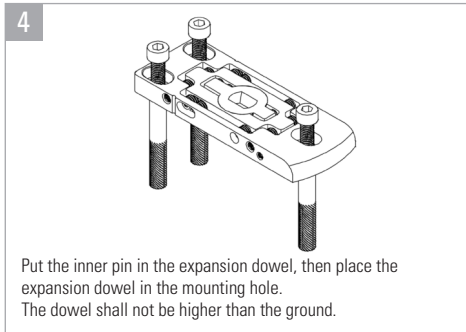

Put the inner pin in the expansion dowel, then place the expansion dowel in the mounting hole. The dowel shall not be higher than the ground.

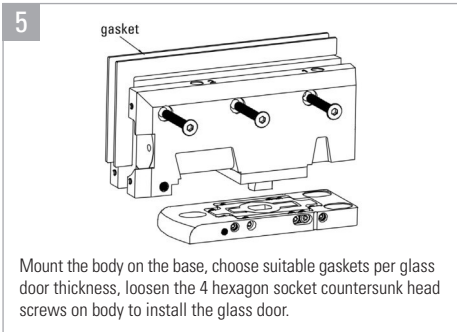

Mount the body on the base, choose suitable gaskets per glass door thickness, loosen the 4 hexagon socket countersunk head screws on body to install the glass door.

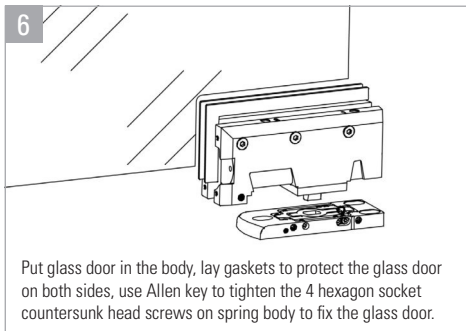

Put glass door in the body, lay gaskets to protect the glass door on both sides, use Allen key to tighten the 4 hexagon socket countersunk head screws on spring body to fix the glass door.

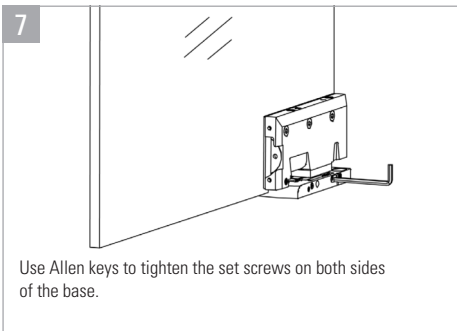

Use Allen keys to tighten the set screws on both sides of the base.

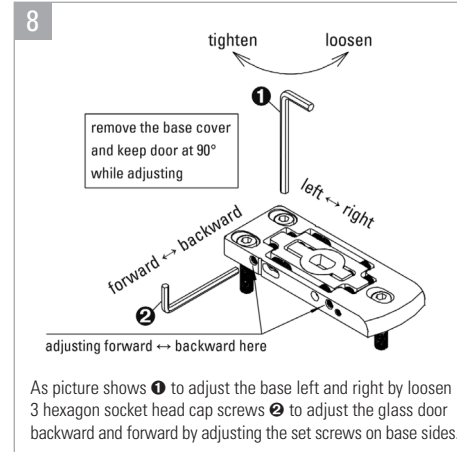

As picture shows ❶ to adjust the base left and right by loosen 3 hexagon socket head cap screws ❷ to adjust the glass door backward and forward by adjusting the set screws on base sides.

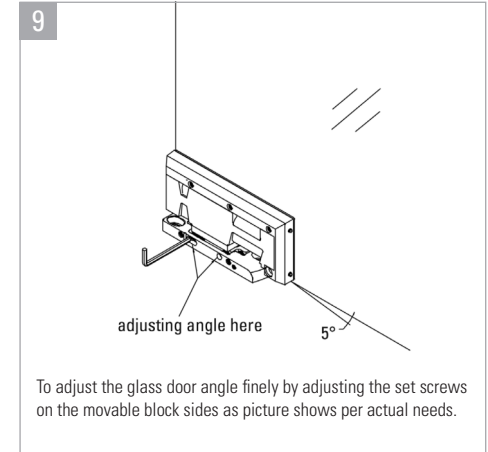

To adjust the glass door angle finely by adjusting the set screws on the movable block sides as picture shows per actual needs.

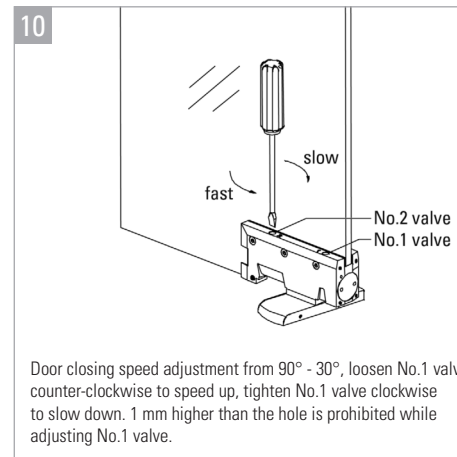

Door closing speed adjustment from 90° - 30°, loosen No.1 valve counter-clockwise to speed up, tighten No.1 valve clockwise to slow down. 1 mm higher than the hole is prohibited while adjusting No.1 valve.

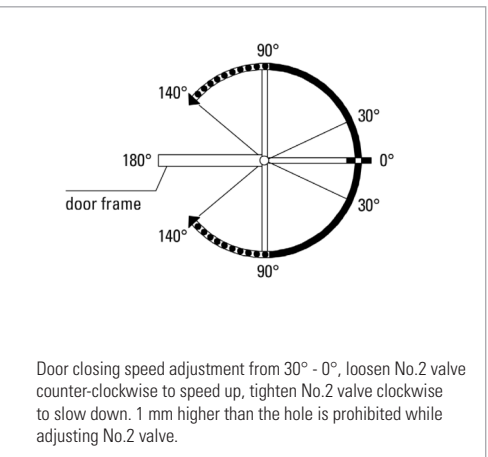

Door closing speed adjustment from 30° - 0°, loosen No.2 valve counter-clockwise to speed up, tighten No.2 valve clockwise to slow down. 1 mm higher than the hole is prohibited while adjusting No.2 valve.

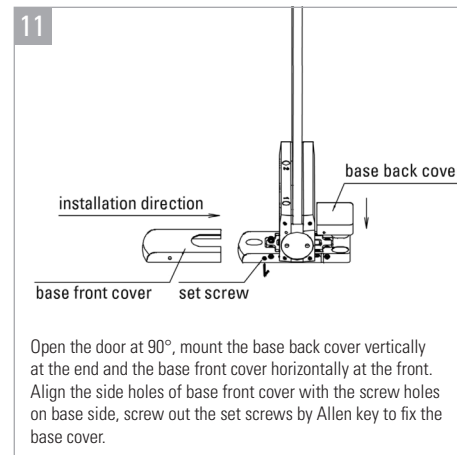

Open the door at 90°, mount the base back cover vertically at the end and the base front cover horizontally at the front. Align the side holes of base front cover with the screw holes on base side, screw out the set screws by Allen key to fix the base cover.

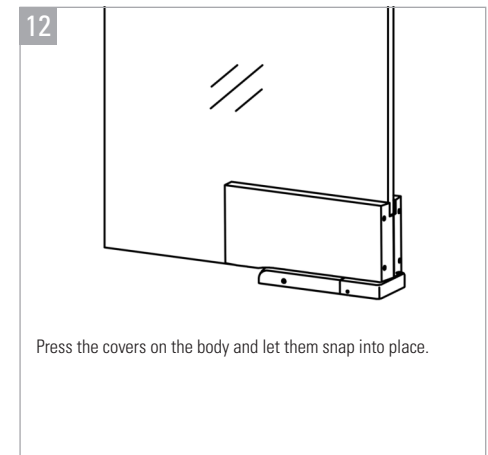

Press the covers on the body and let them snap into place.